

Instrukcja montażu



Uszczelnienia bramowe

30016.1004.U.01





SHV / TAB

element dostarczany przez innych dostawców

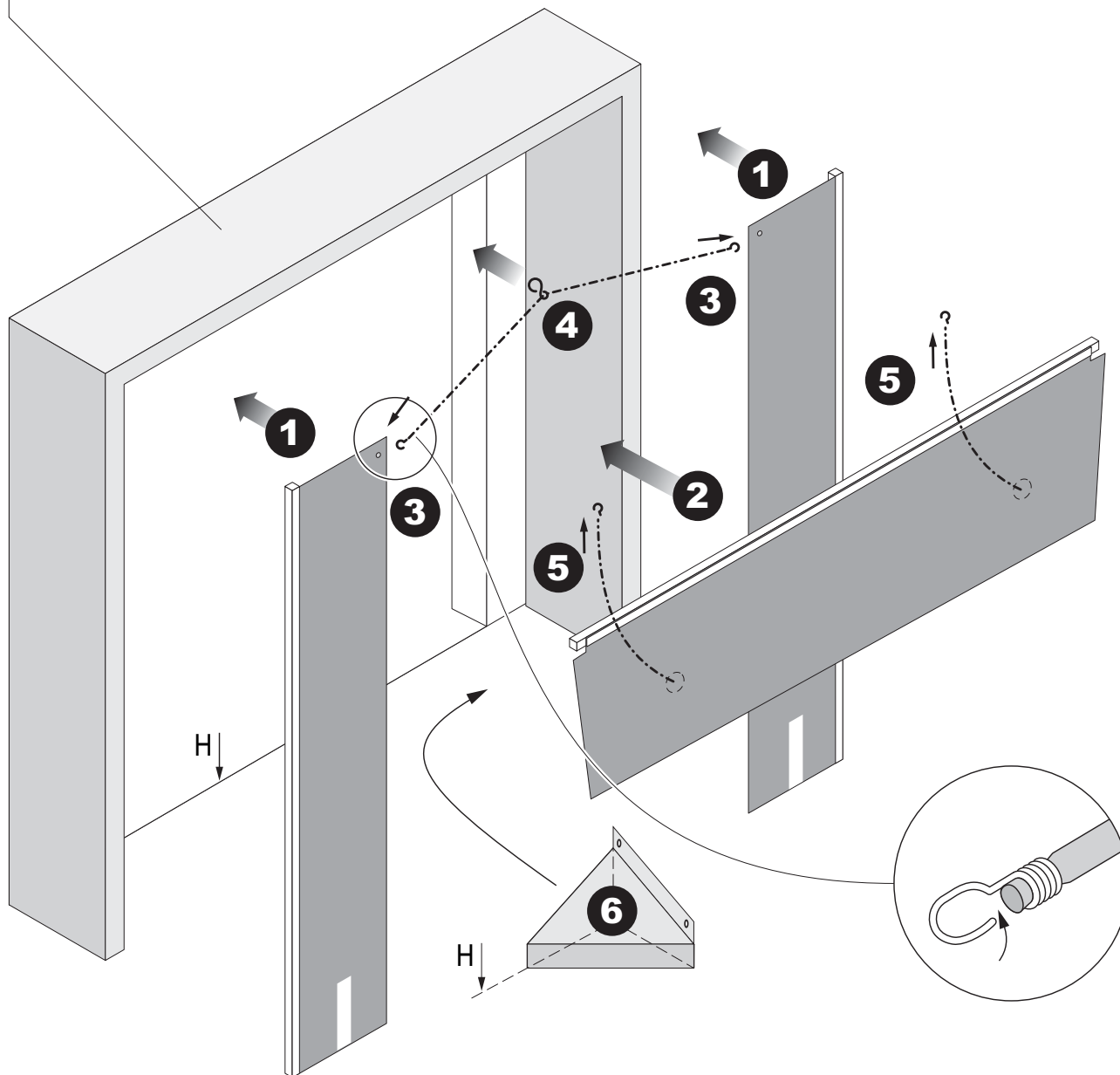

Zwiększenie napięcia sprężyny

A Trzpień $\varnothing 8$

B Ramię sprężyny skrętej

C Bolec zabezpieczający

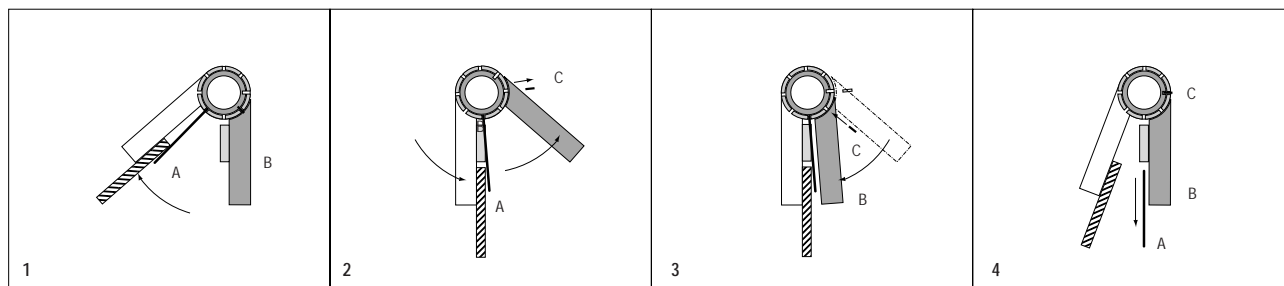

30016_1004_U_01

dostawca zastrzega sobie prawo do wprowadzania zmian technicznych

SHD / TAB

element dostarczany przez innych dostawców

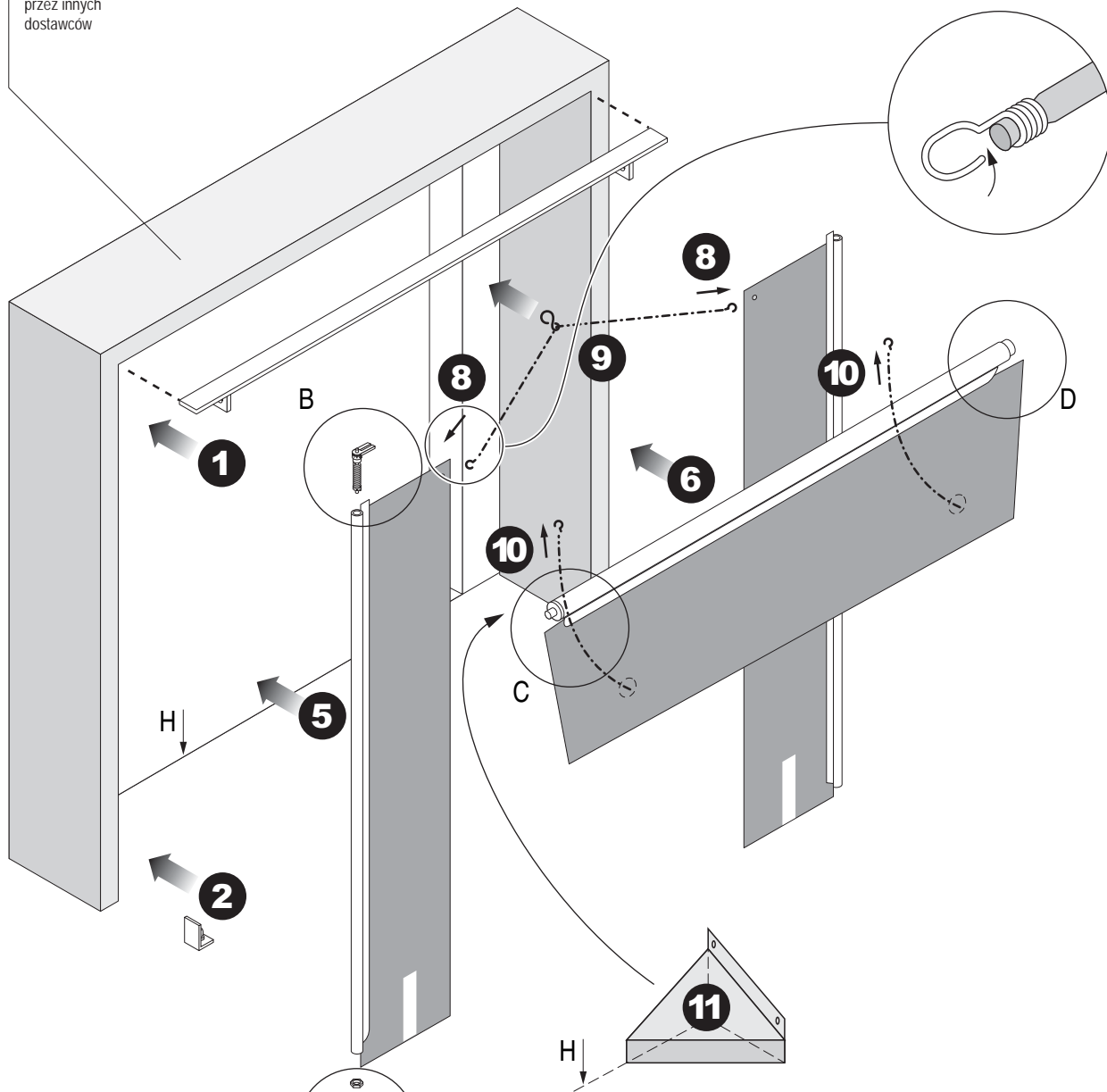

Zwiększenie napięcia sprężyny :
patrz str. 2 lub 4

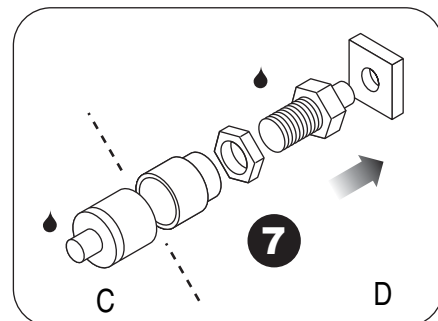
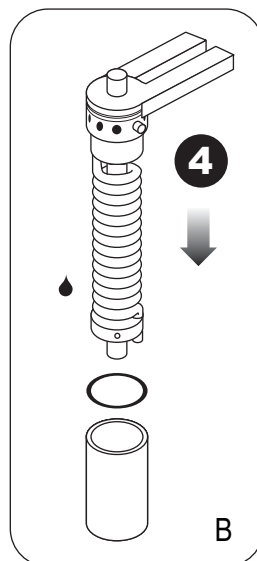
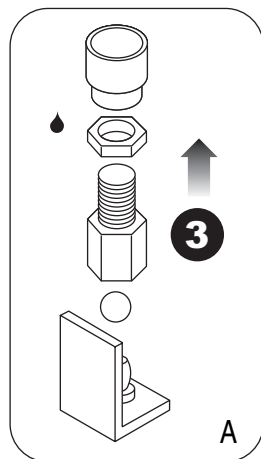



SHVP / TAF

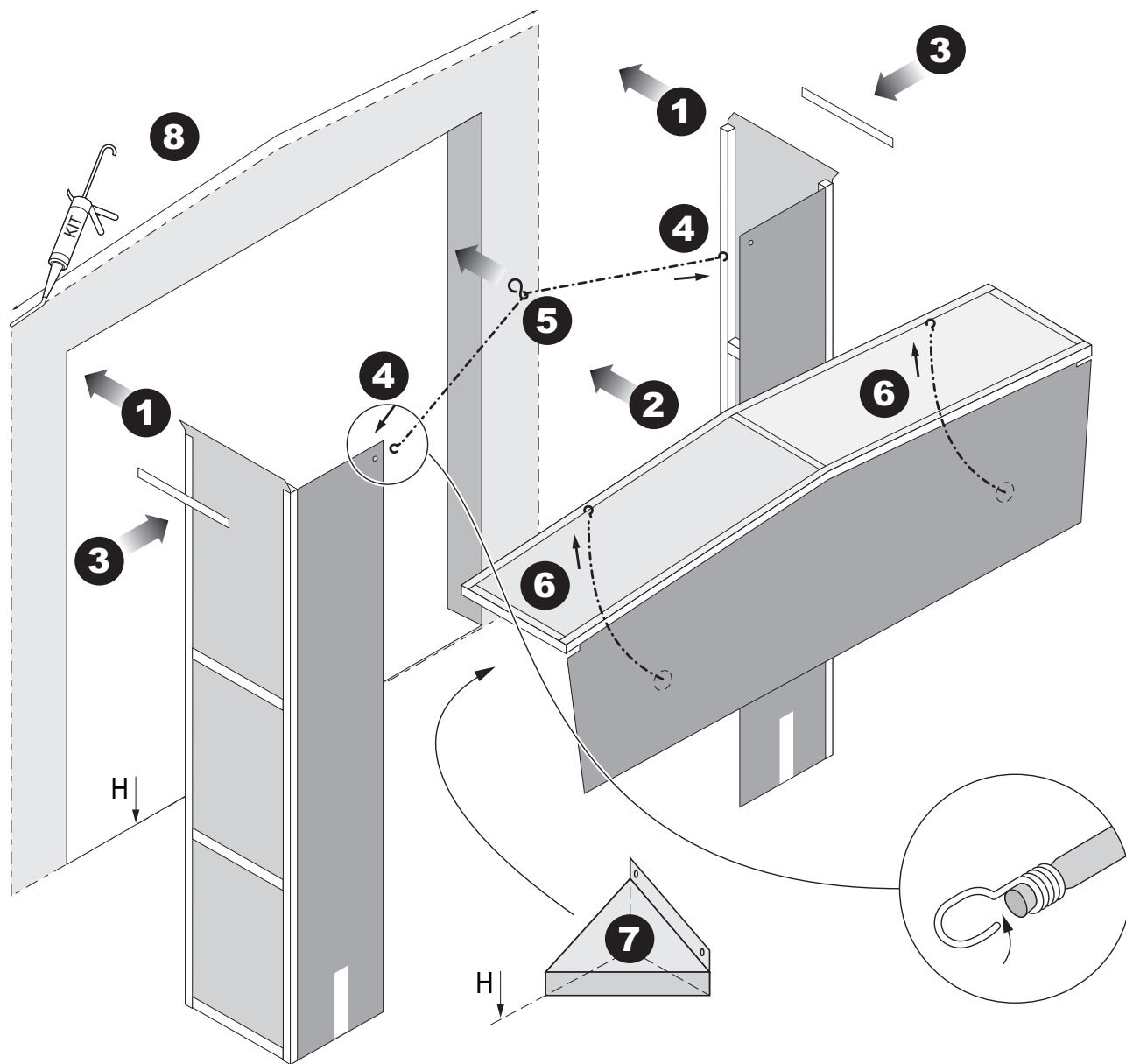

Zwiększenie napięcia sprężyny

A Trzpień $\varnothing 8$

B Ramię sprężyny skrętej

C Bolec zabezpieczający

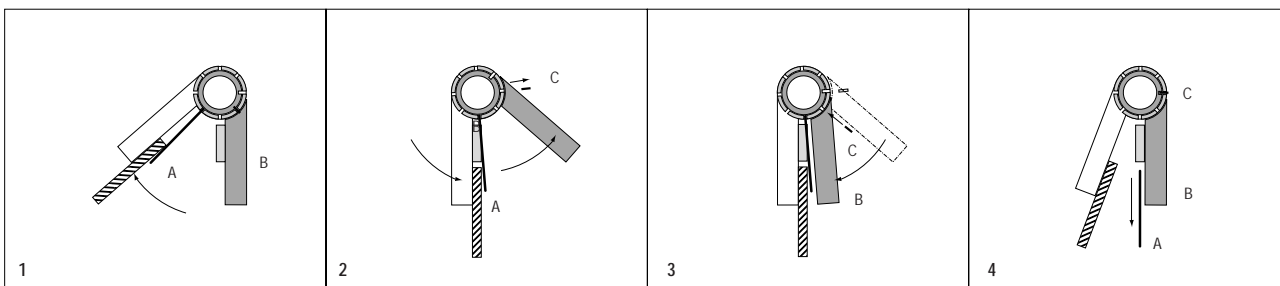

SHDP / TAF

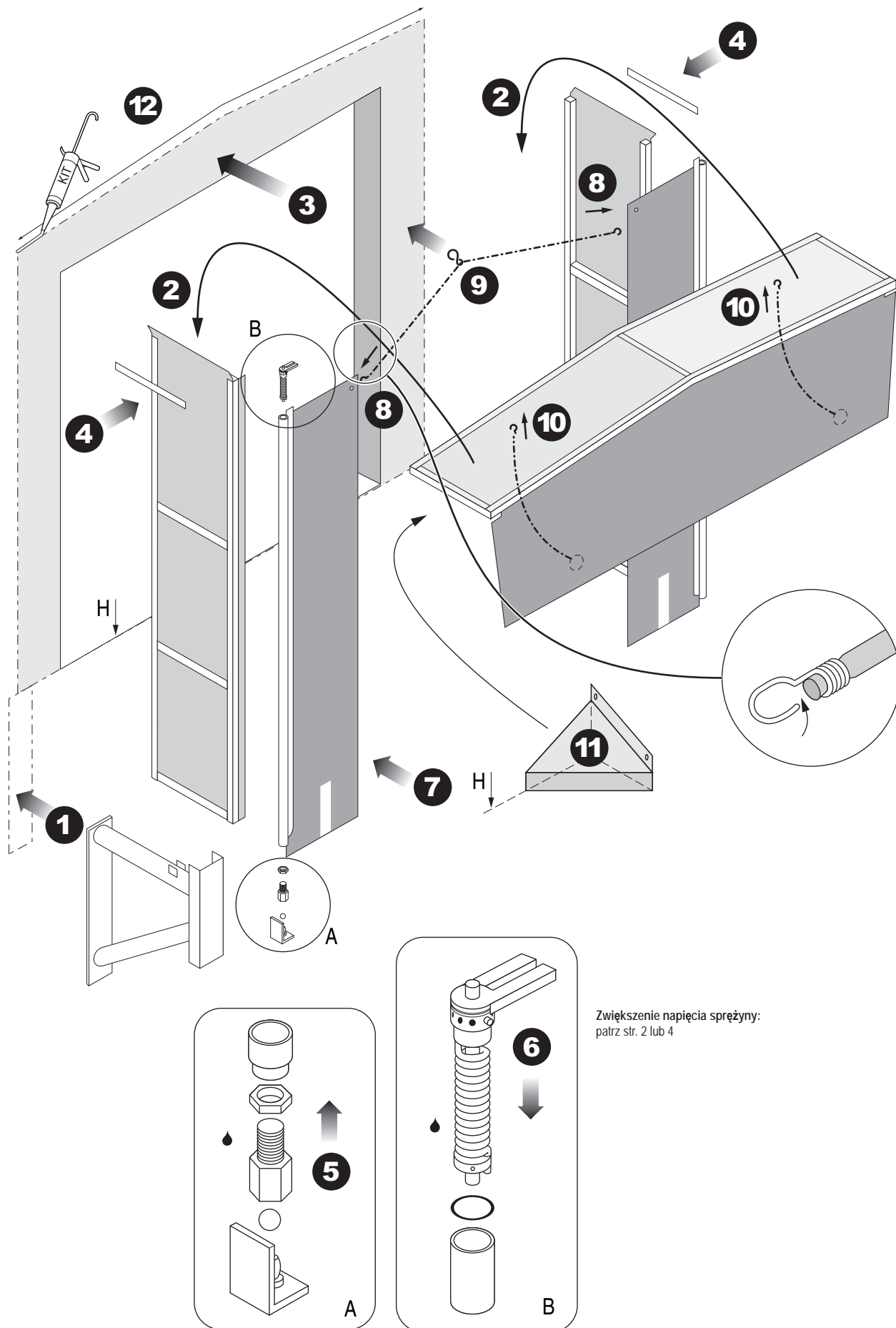



SHVPI / TAE

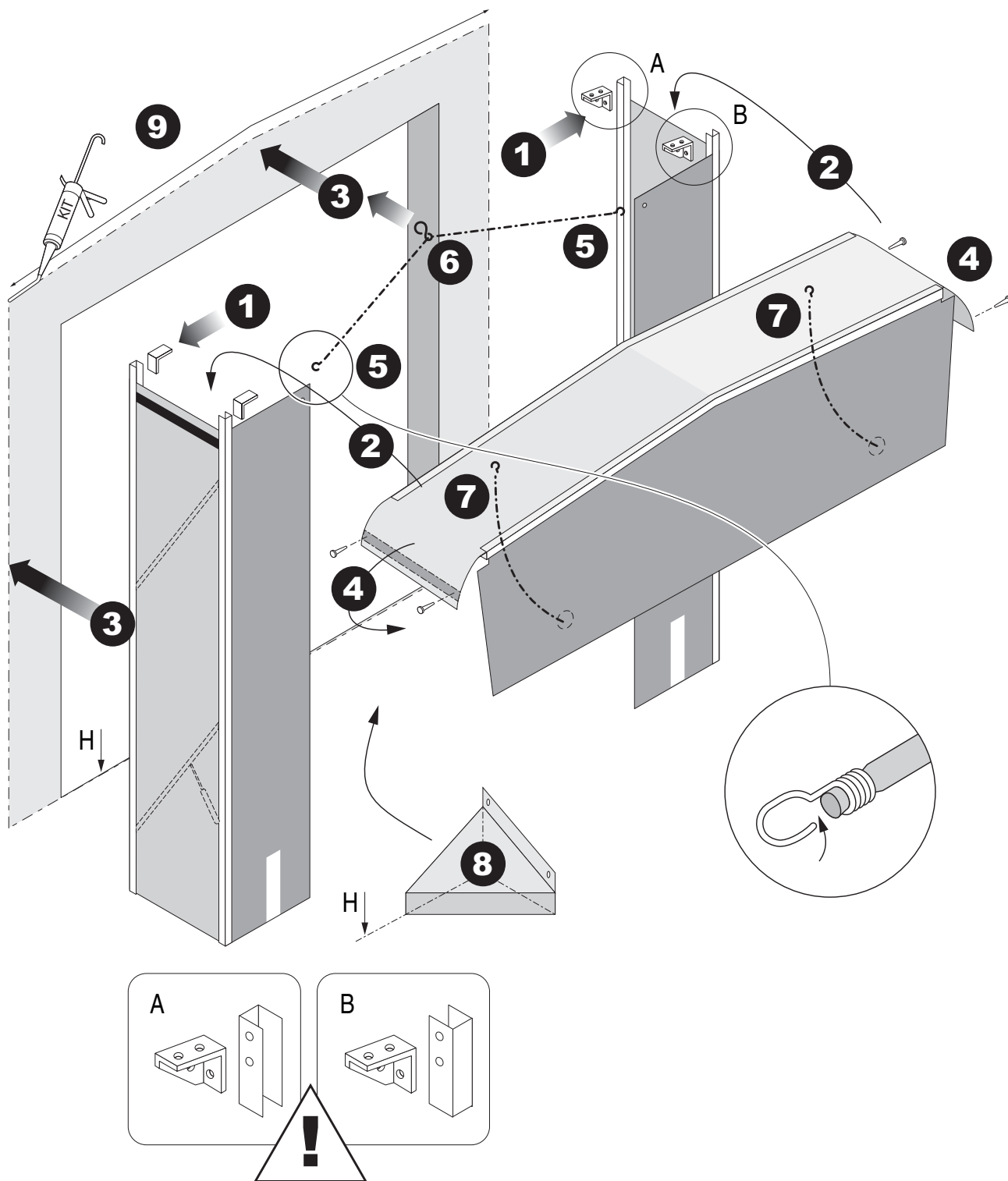



SHVPI-F / TAE-F

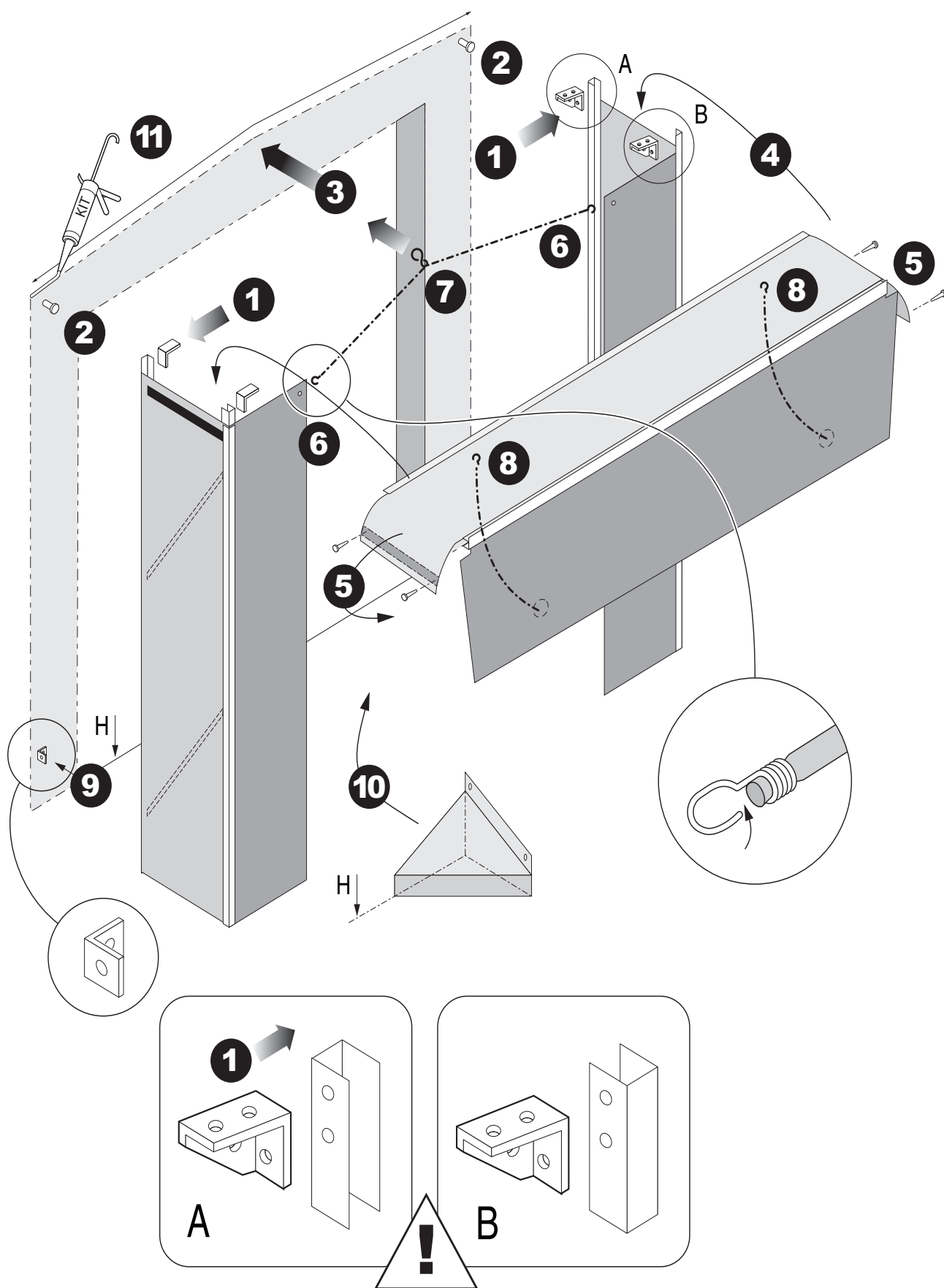



SHD

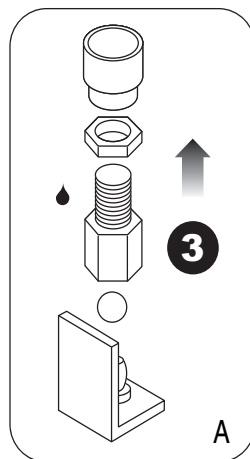
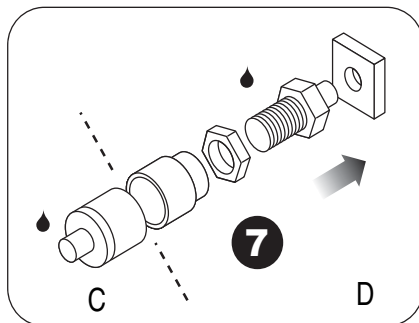
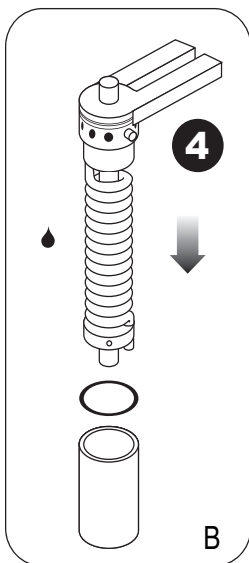
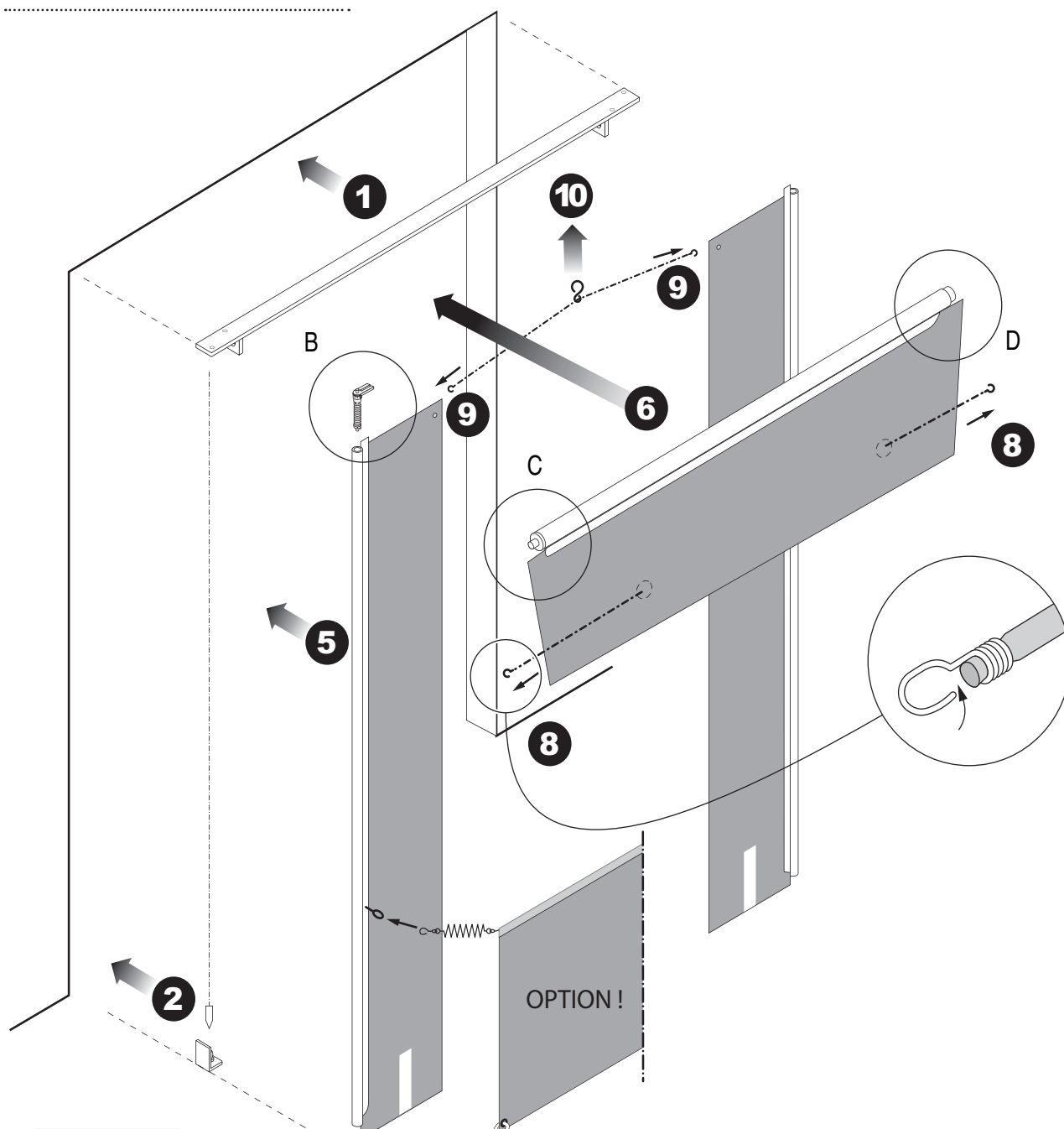

Zwiększenie napięcia sprężyny :
patrz str. 2 lub 4

